

THIS DRAWING IS UNPUBLISHED. RELEASED FOR PUBLICATION
 © COPYRIGHT - By - ALL RIGHTS RESERVED.

LOC	DIST	REVISIONS					
AF	50	P	LTR	DESCRIPTION	DATE	DWN	APVD
		F		REVISED PER ECR-12-013459	29NOV2012	KH	PD

- 1 CONTINUOUS STRIP ON REELS
- 2 MATING TAB THK IS $.032 \pm .001$
- 3 WIRE SIZE IS #18-#14 AWG
- 4 INSULATION RANGE IS $.060-.110$ DIA.
- 5  PRELIMINARY - NOT FOR PRODUCTION

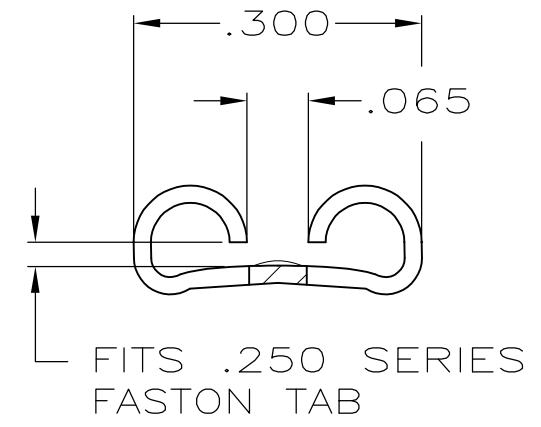
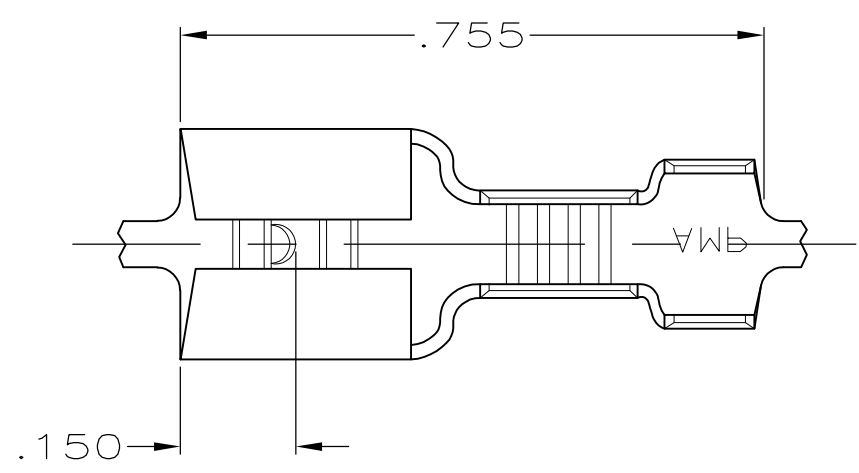

VIEW A-A
SCALE 5:1

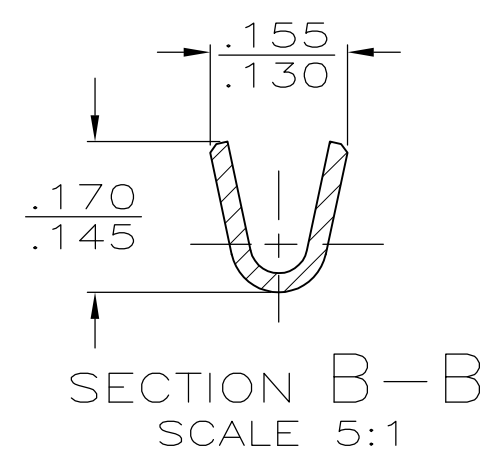
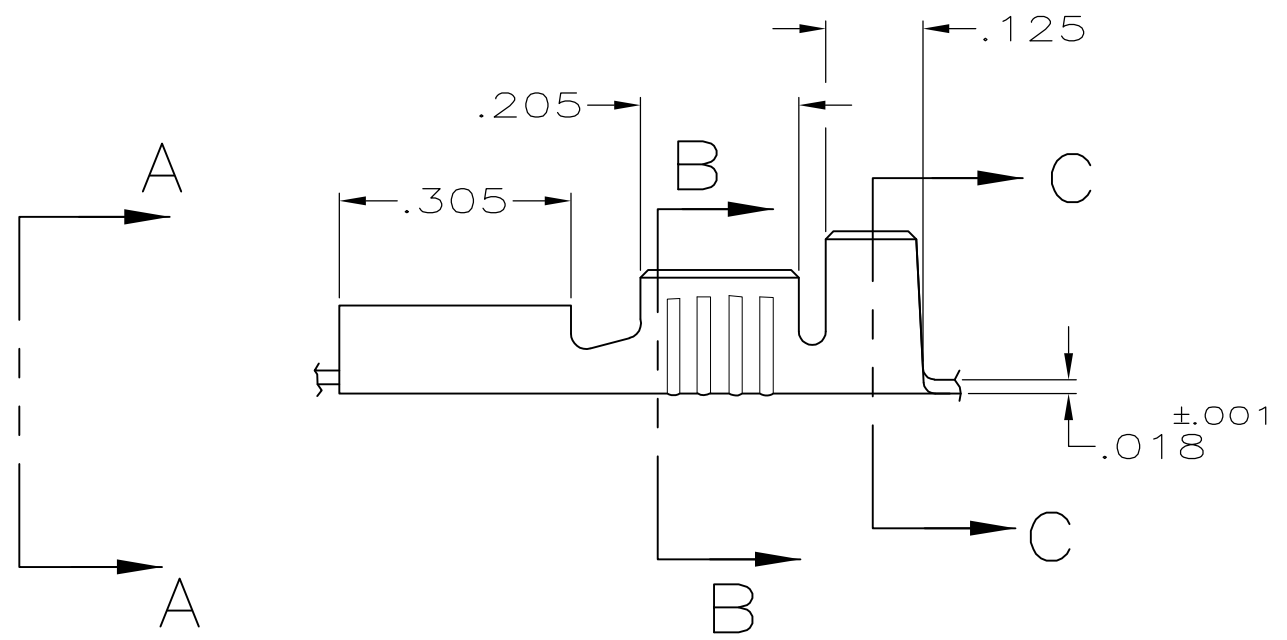

SECTION B-B
SCALE 5:1

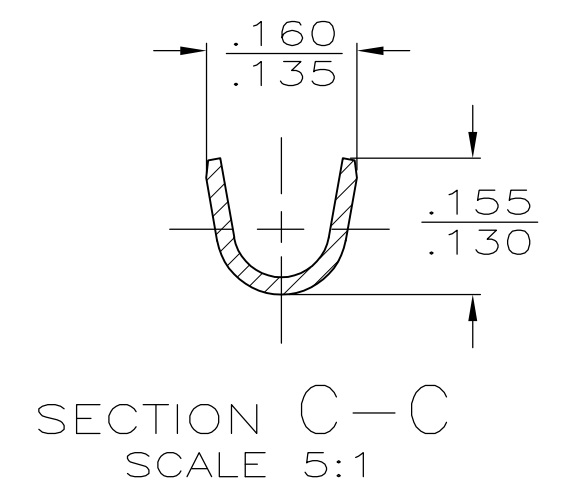

SECTION C-C
SCALE 5:1

TIN	H03 PHOS BRONZE		61375-3
TIN	BRASS		61375-1
FINISH	MATERIAL		PART NO

F	.120	.252	F	.120	.075	14
					.066	16
					.061	18
TYPE	WIDTH	STRIP LENGTH ±.015	TYPE	WIDTH	±.002 HEIGHT	WIRE
INSUL BARREL CRIMP			WIRE BARREL CRIMP			

THIS DRAWING IS A CONTROLLED DOCUMENT.

DIMENSIONS: INCHES

TOLERANCES UNLESS OTHERWISE SPECIFIED:

0 PLC	± -
1 PLC	± -
2 PLC	± -
3 PLC	± .015
4 PLC	± -
ANGLES	± -

MATERIAL: SEE TABLE

FINISH: SEE TABLE

DWN: JR RUTH 7/10/89

CHK: MS FEHER 7/10/89

APVD: C MEYERS 7/10/89

PRODUCT SPEC: -

APPLICATION SPEC: -

WEIGHT: -

CUSTOMER DRAWING

STE TE Connectivity

RECEPTACLE, FASTON™
.250 SERIES

SIZE	CAGE CODE	DRAWING NO	RESTRICTED TO
A3	00779	C-61375	-

SCALE: 4:1 SHEET: 1 OF 1 REV: F